

Volkswagen

Golf VII

 2013-

5G

56144E

Type: KD328

Approval No: E11 55R-01 8234

Coupling class : A50-X

D= 9.9kN(max)

S= 80kg(max)

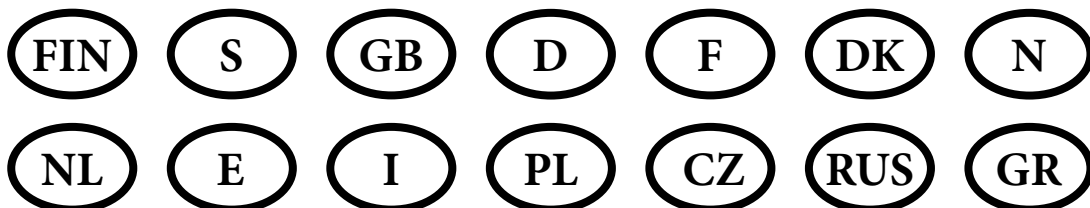
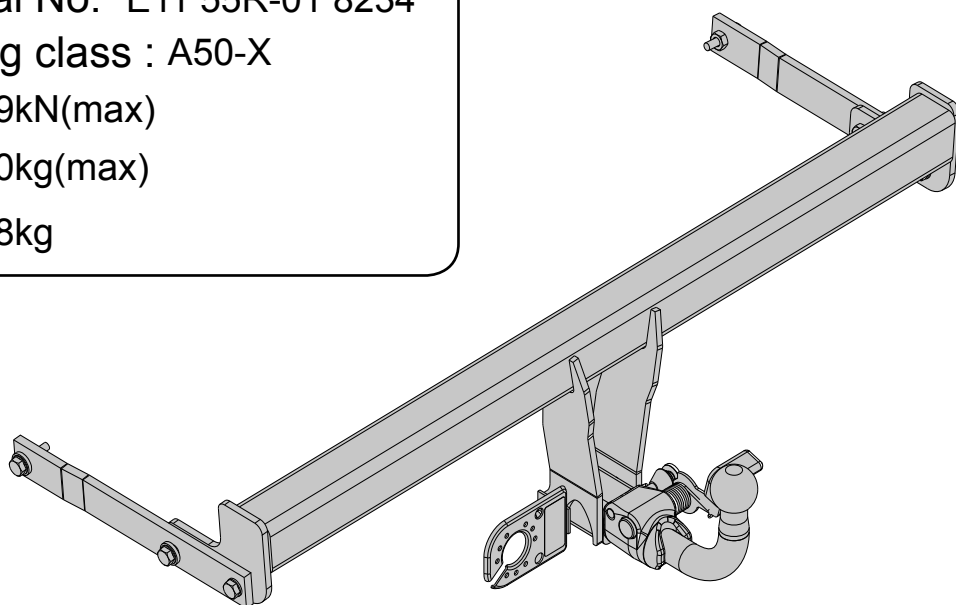
 kg 18kg



Vetokoukun asennusohje

Asiakkaan tulee ennen asennuksen aloittamista perehtyä huolellisesti näihin ohjeisiin. Kiiinnityssarjan sisältöä ja asennusoppaita voidaan muuttaa siitä etukäteen ilmoittamatta. Jos asennuksen suorittaa joku muu kuin pätevä ammattilainen, tämä kumoo asiakkaan oikeuden vahingonkorvauksiin, erityisesti sellaisiin, jotka perustuvat tuotevastuulakiin.



Monteringsinstruktion för släpvagnskoppling

Vänligen läs dessa anvisningar noga innan du påbörjar monteringen. Innehållet i dessa satser och deras bruksanvisningar kan komma att ändras utan föregående meddelande. Vi vill uttryckligen meddela att montering som inte görs fackmannamässigt av en kompetent montör, kommer att häva rätten till kompensation för skador, speciellt rättigheter enligt lagen om produktansvar.



Installation instructions for trailer coupling

Please ensure that these instructions are read and fully understood before commencing installation. Contents of these kits and their fitting manuals are subject to alteration without notice. We would expressly point out that assembly not carried out properly by a competent installer will result in cancellation of any right to damage compensation, in particular those arising by virtue of the product liability act.



Einbauanleitung für Anhängerkupplung

Lesen Sie vor dem Einbau diese Anleitung sorgfältig und gewissenhaft durch. Das Recht zu Änderungen an Inhalt von Montagesatz und Einbauanleitungen ohne Vorankündigung bleibt vorbehalten. Beachten Sie bitte, dass bei Schäden in Folge unsachgemäßen Einbaus sämtliche Garantieansprüche erlöschen, insbesondere solche, die das Produkthaftungsgesetz betreffen.



Instructions de montage pour dispositif d'attelage de remorque

Lisez attentivement ces instructions avant de procéder à l'installation. Le contenu de ces kits, ainsi que des guides de montage qui les accompagnent est sujet à modifications sans préavis. Nous tenons à insister tout particulièrement sur le fait que si ce produit n'est pas correctement assemblé par un technicien compétent, aucun droit de compensation ne sera recevable en cas de dommages, notamment les droits en vertu de la loi concernant la responsabilité à l'égard des produits.



Monteringsvejledning til anhængerkobling

Vejledningerne skal derfor læses og forstås, før monteringen påbegyndes. Sættenes indhold og monteringsvejledninger kan ændres uden varsel. Det skal understreges, at montering, der udføres af en ikke-kvalificeret montør, medfører bortfald af enhver ret til erstatning særligt i forbindelse med erstatningskrav, der måtte opstå i kraft af loven om produktansvar.



Monteringsveiledning for tilhengerfeste

Vennligst påse at disse instruksjonene leses grundig og er forstått innen installasjonen startes. Innholdene i disse sett og deres monteringsanvisninger kan endres uten forvarsel. Vi bemerker at montasje som ikke utføres korrekt, av en kompetent installatør, vil resultere i annullering av all rett til erstatning for enhver skade, spesielt de som oppstår av arten produktansvar.



Montageaanwijzing voor trekhaak

Zorg er dus voor dat u deze instructies hebt gelezen en volledig begrijpt voordat u met de installatie begint. De inhoud van deze kits en de installatiehandleidingen kunnen worden gewijzigd zonder kennisgeving. We zouden expliciet willen benadrukken dat installatie die niet correct wordt uitgevoerd door een bekwame installateur kan leiden tot het vervallen van elk recht op schadecompensatie, vooral de compensatie op basis van de productaansprakelijkheids-overeenkomst.



Instrucciones de montaje para acoplamiento del remolque

Es importante que lea con atención todas las instrucciones y que las entienda perfectamente antes de iniciar la instalación. El contenido de los kits y sus correspondientes manuales de montaje están sujetos a posibles modificaciones sin previo aviso. Una vez más, hacemos hincapié en el hecho de que si este producto no lo monta correctamente un técnico instalador cualificado, se anulará cualquier derecho de compensación por posibles daños, especialmente los relativos a la legislación vigente sobre este tipo de productos.



Istruzioni di montaggio per dispositivo di rimorchio

Si raccomanda di leggere attentamente e integralmente tali istruzioni e di sincerarsi di averle comprese prima di procedere all'installazione. I contenuti di questi kit e i relativi manuali di installazione sono soggetti a modifica senza preavviso. Si prega di notare che, in caso di installazione scorretta non eseguita da un installatore competente, l'utente perderà ogni diritto a un eventuale rimborso danni e, specificamente, ogni diritto previsto dalle leggi sulla responsabilità di prodotto.



Instrukcja montażu zaczepu holowniczego

Przed rozpoczęciem instalacji należy zapoznać się z instrukcjami i upewnić się, że zostały zrozumiane. Zawartość opisywanych zestawów i instrukcje ich montażu mogą ulegać zmianom bez powiadomienia. Pragniemy zwrócić uwagę na fakt, że nieprawidłowy montaż przeprowadzony przez niekompetentne osoby będzie podstawą do nieważnienia wszelkich praw do odszkodowań, w szczególności wynikających z ustaw o odpowiedzialności za produkt.



Návod k montáži spojky přívěsu

Prosím, ujistěte se, že jste si pokyny před instalací přečetly a dostatečně jim rozumíte. Obsah těchto sad a návody na jejich montáž podléhají změnám bez předchozího upozornění. Upozorňujeme, že instalace provedená nesprávně nebo nekompetentní osobou, ruší veškerá práva na kompenzaci škod, obzvláště způsobených poruchou produktu.



Инструкция по установке тягово-сцепного устройства

Внимательно прочитайте инструкцию перед тем, как начать установку. Право изменения содержания монтажного комплекта и инструкции по установке без предварительного оповещения производитель оставляет за собой. Обратите при повреждении, возникших в результате неправильного монтажа, истекают все виды гарантии, в частности, касающиеся закона, регулирующего ответственность за качество продукции.



Εγχειρίδιο τοποθέτησης για μηχανισμό σύζευξης ρυμουλκούμενου

Βεβαιωθείτε ότι ο οδηγός αυτές έχουν Α:Β:С διαβάσει και έχουν γίνει απολύτως κατανοητές προτού ξεκινήσετε την εγκατάσταση. Τα περιεχόμενα αυτών των kit και τα εγχειρίδια τοποθέτησης υπόκεινται σε αλλαγές χωρίς προειδοποίηση. Θα πρέπει να τονιστεί ότι συναρμολόγηση που δεν πραγματοποιείται σωστά και από ειδικευμένο εγκαταστάτη οδηγεί σε ακύρωση των όποιων δικαιωμάτων αποζημίωσης έναντι ζημίας και ιδιαίτερα αυτών που προκύπτουν σύμφωνα με το νόμο περί ευθύνης προϊόντος.

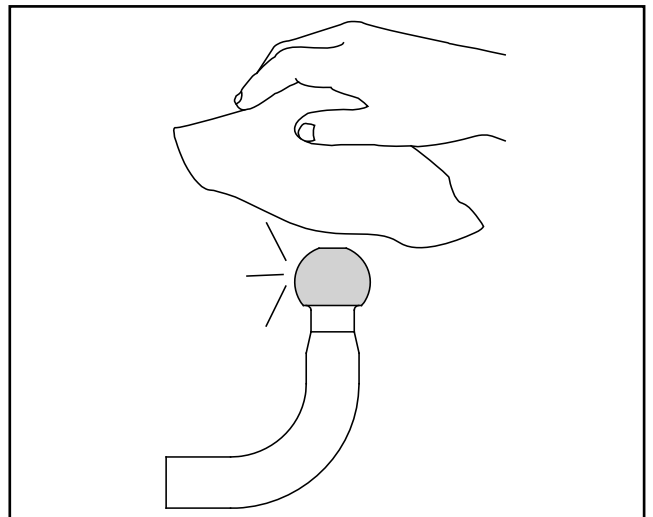
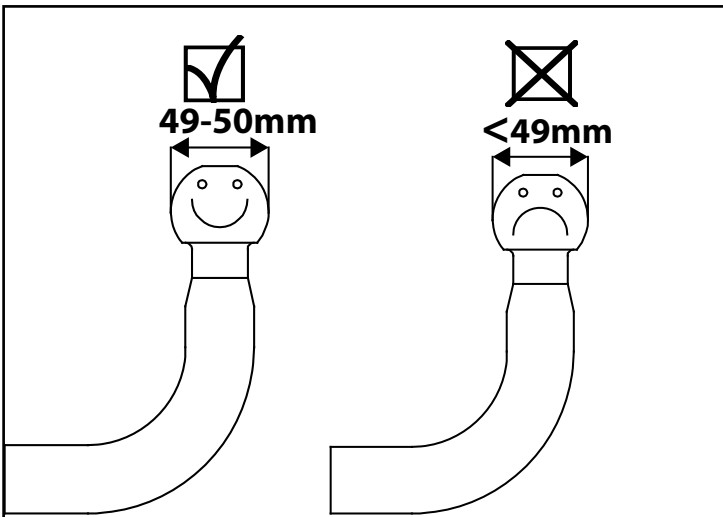
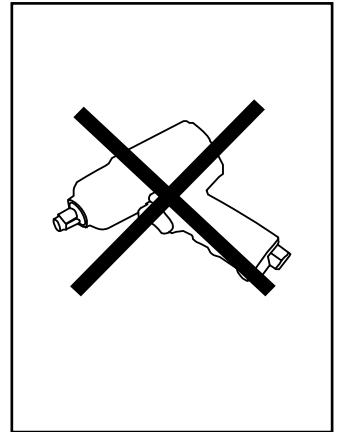
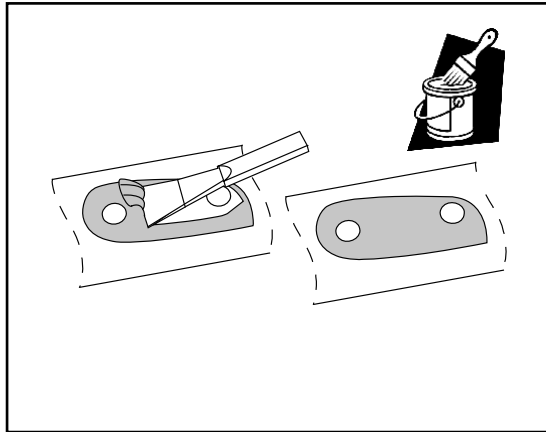
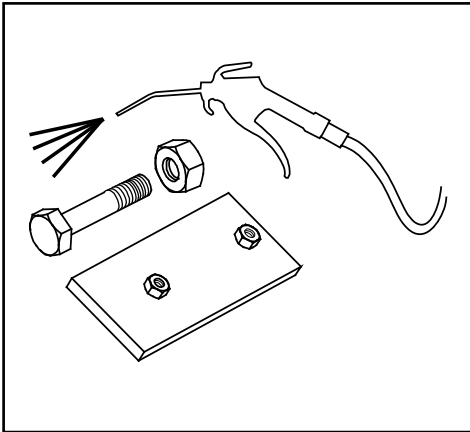
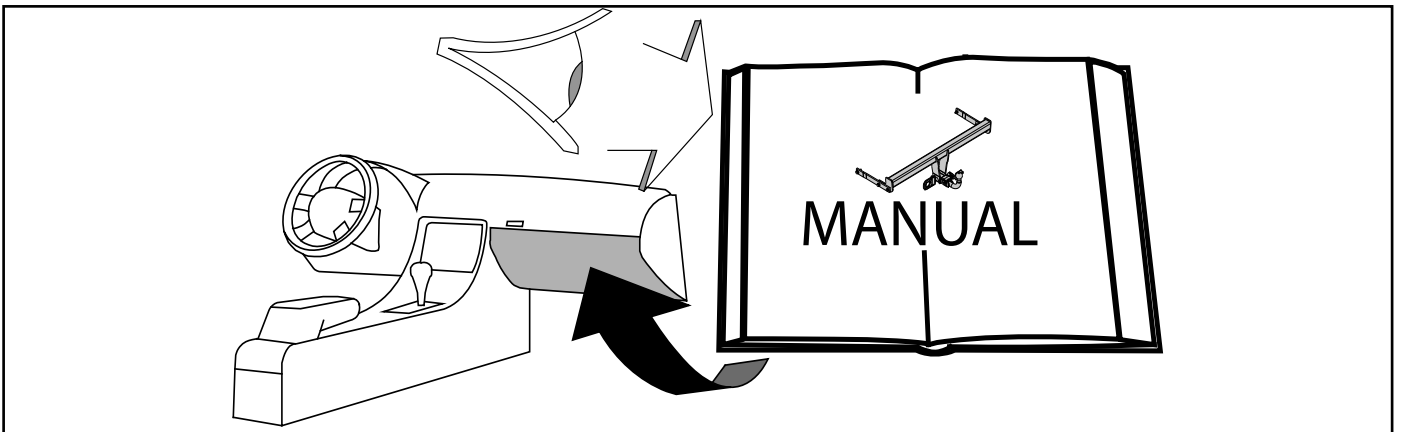
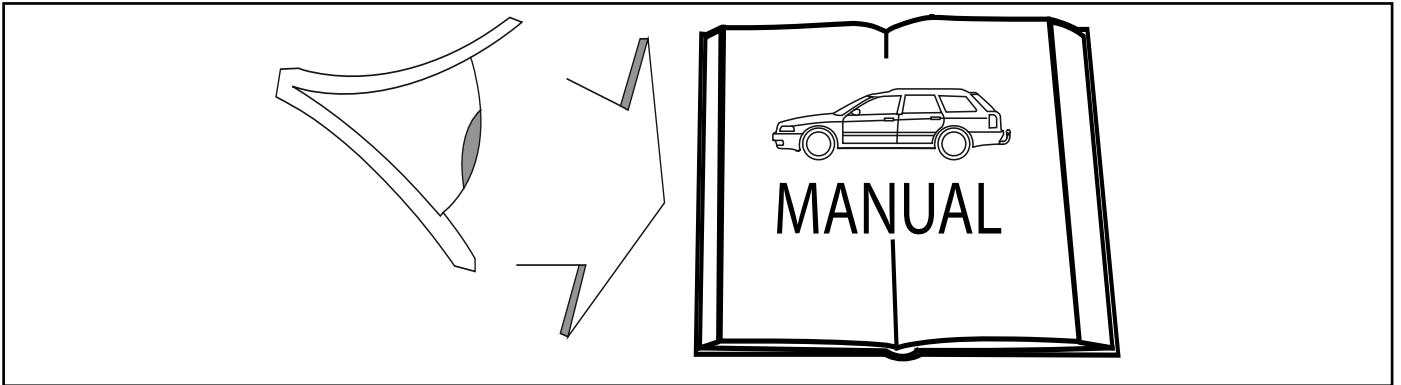

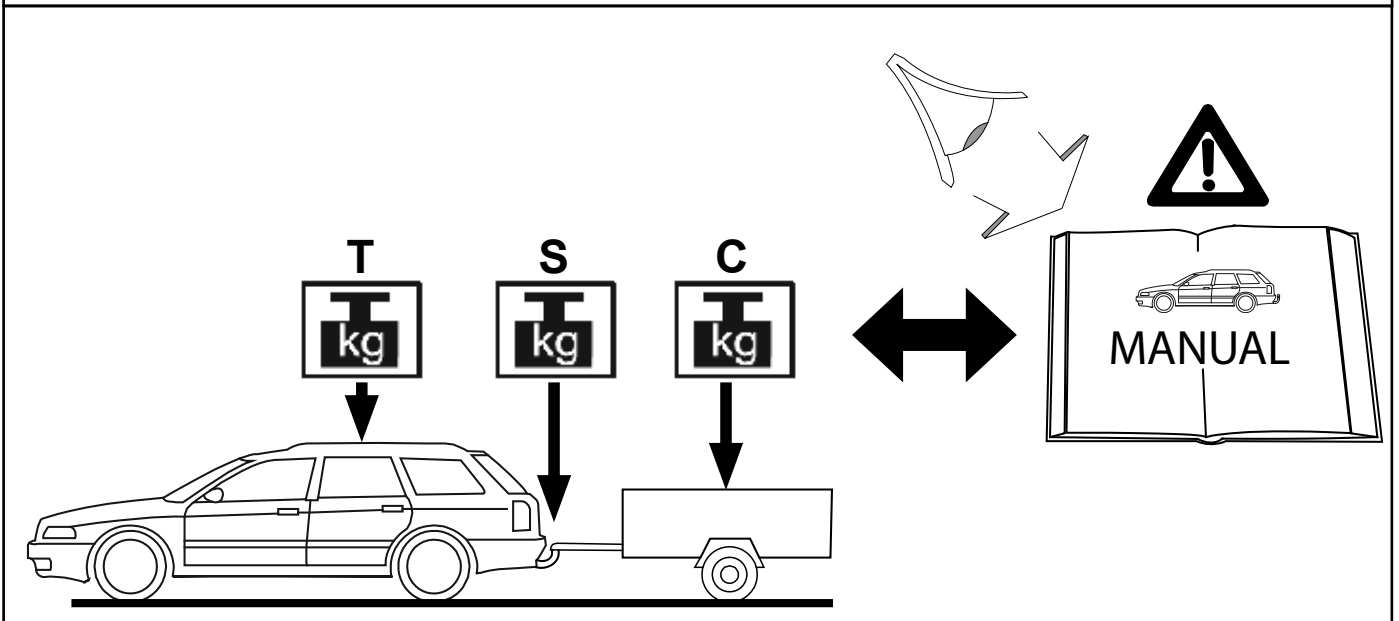
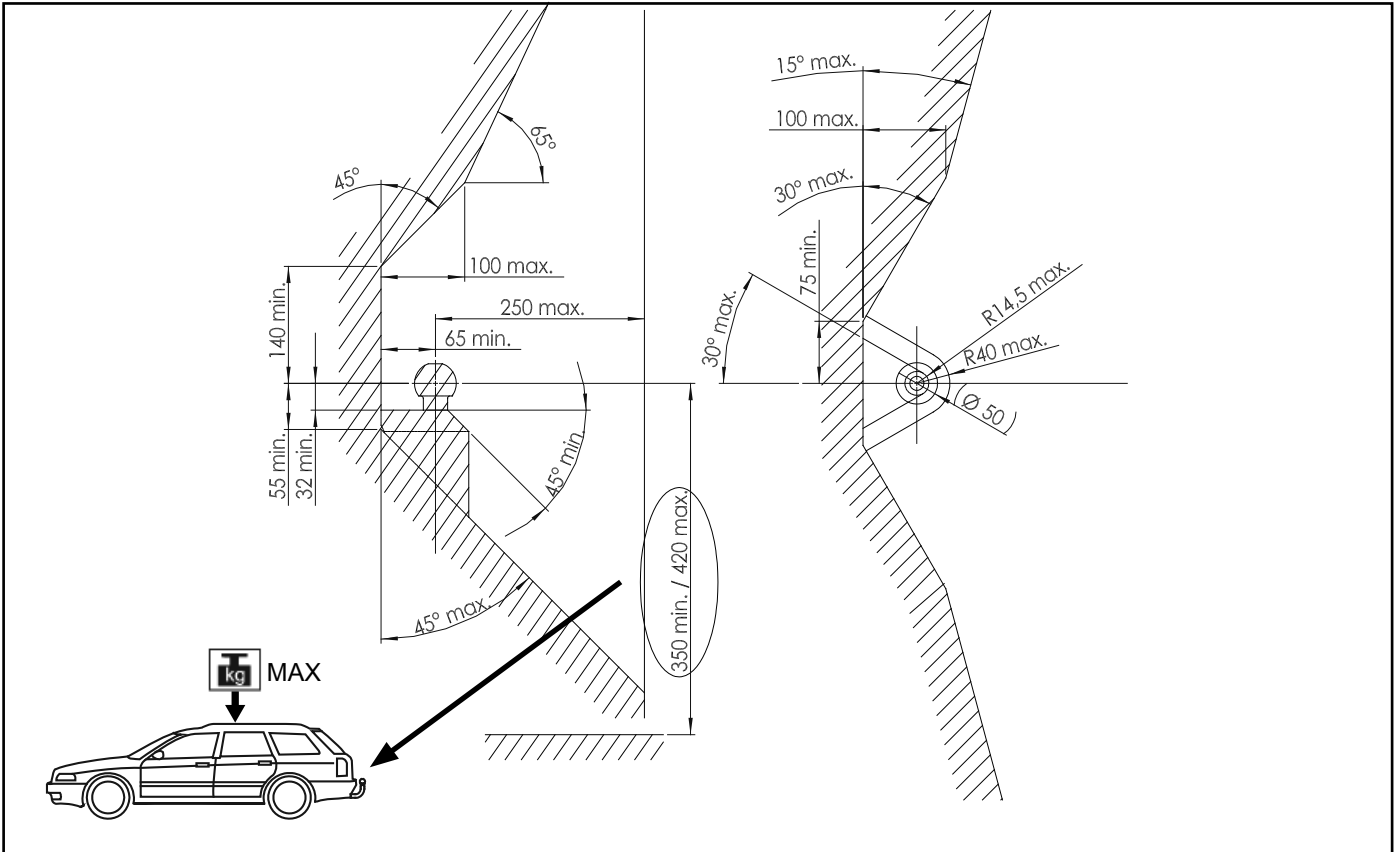

$D = 9.9 \text{ kN (max)}$

$S = 80 \text{ kg (max)}$

$T = 2037 \text{ kg}$

$C = 2000 \text{ kg}$

$$D = \frac{T \times C}{T + C} \times \frac{9,81}{1000}$$

$$T = \frac{C + D}{0,00981 \times C - D}$$

$$C = \frac{T + D}{0,00981 \times T - D}$$

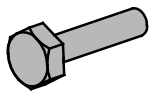
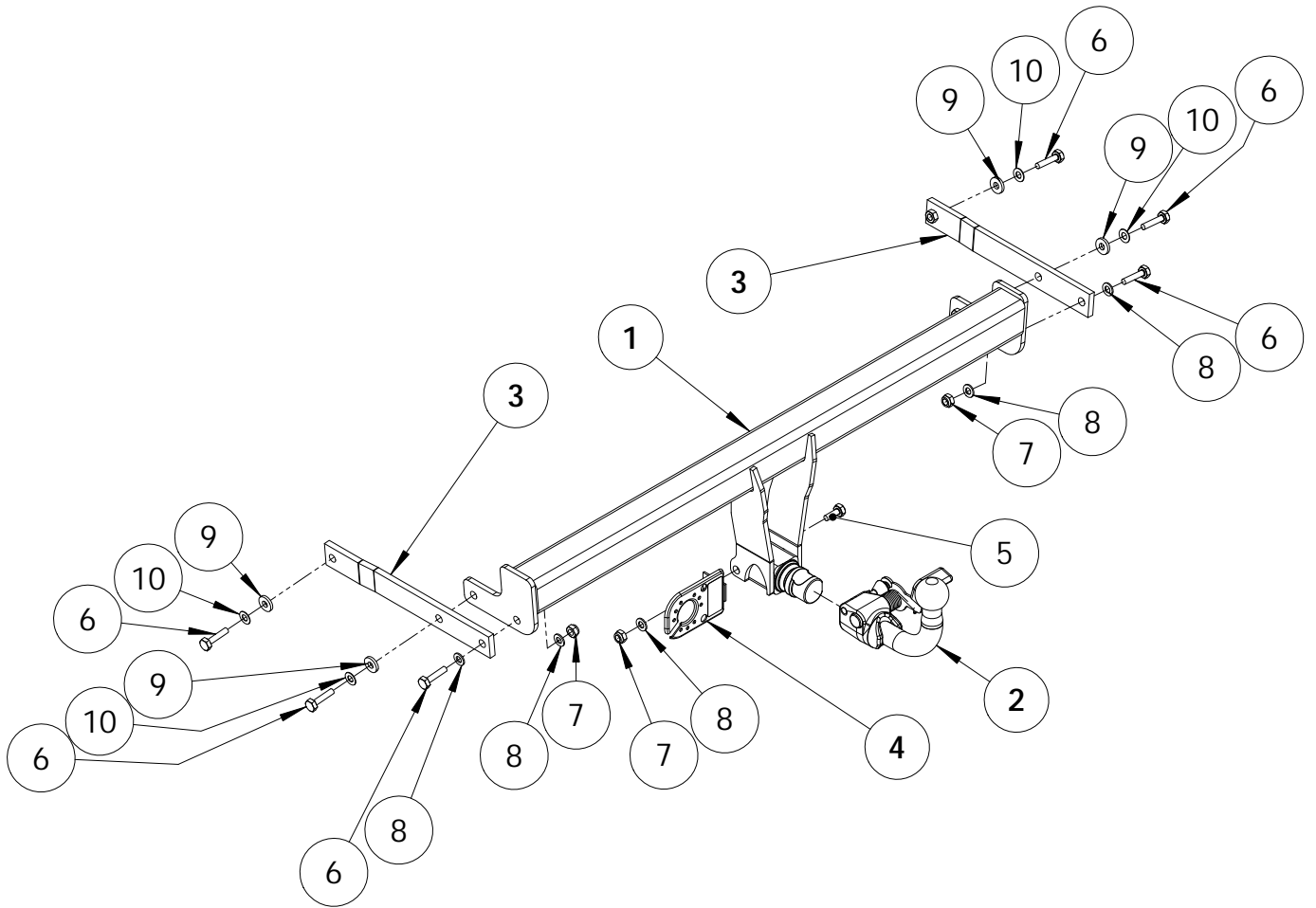

5. M10x25 - (x1)
6. M10x40 - (x6)



7. M10 - (x3)



8. 10,5x20 - (x5)



9. 10,5x25x4 - (x4)



10. M10 - (x4)

2. KE-1



M6 - 8.8 =	10Nm
M8 - 8.8 =	30Nm
M10 - 8.8 =	47Nm
M12 - 8.8 =	90Nm
M14 - 8.8 =	130Nm
M16 - 8.8 =	195Nm
M10 x 1,25 - 8.8 =	40Nm
M12 x 1,25 - 8.8 =	70Nm
M12 x 1,5 - 8.8 =	80Nm

01

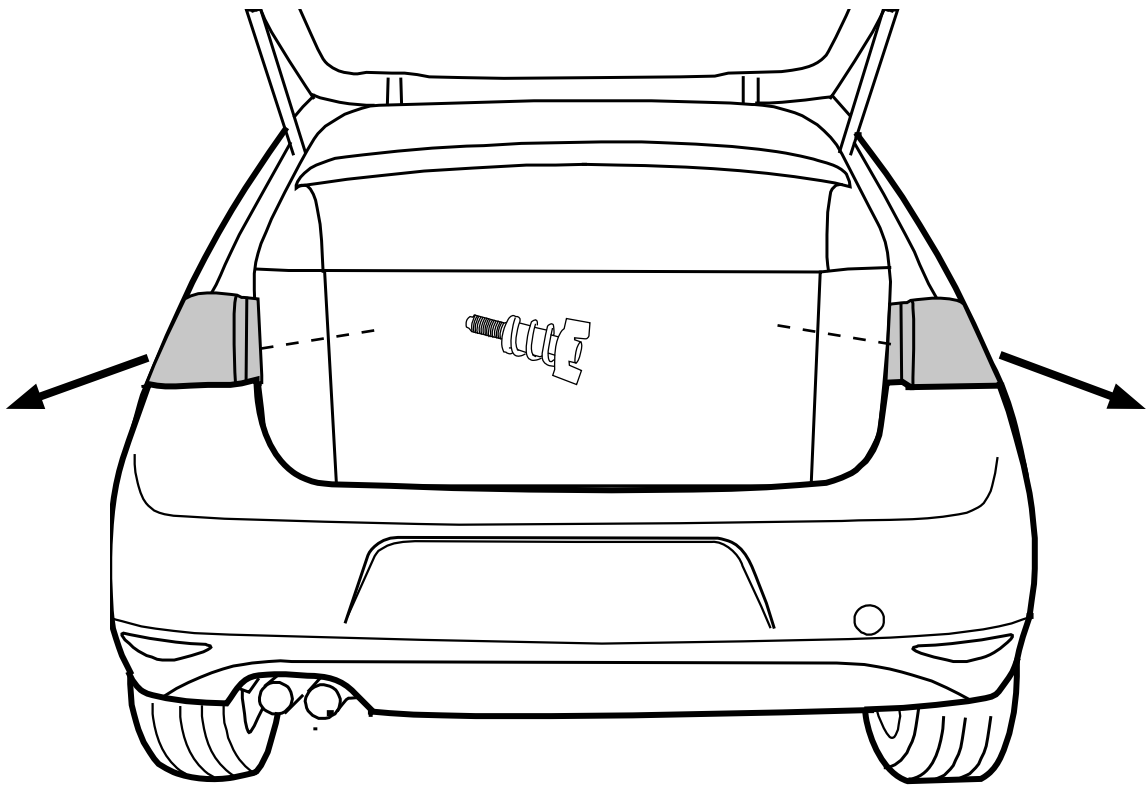

02

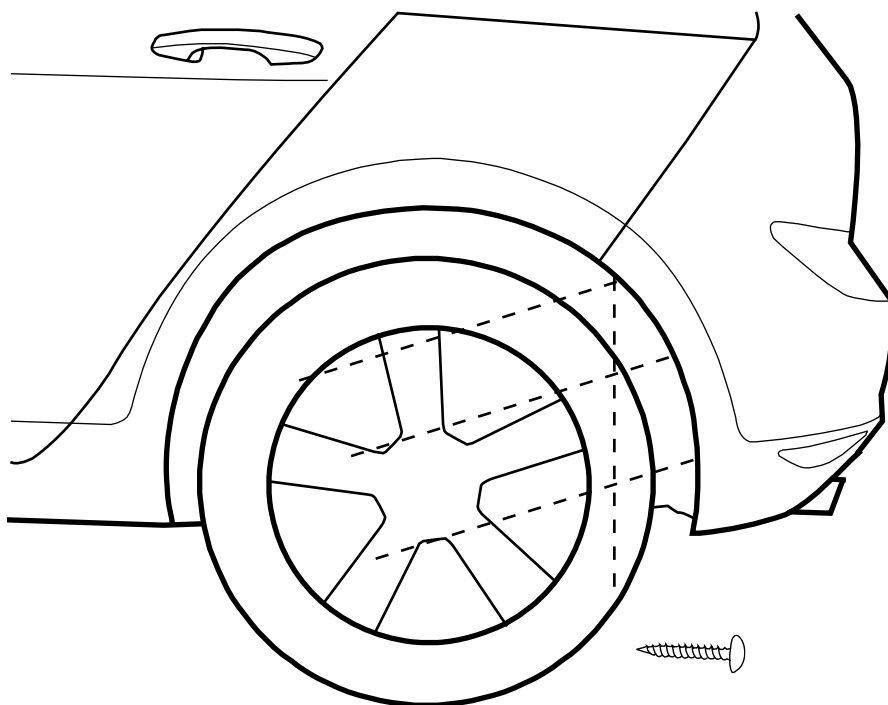
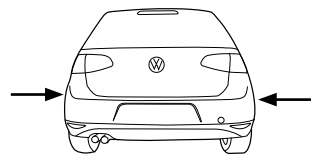
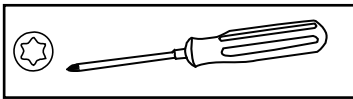

03

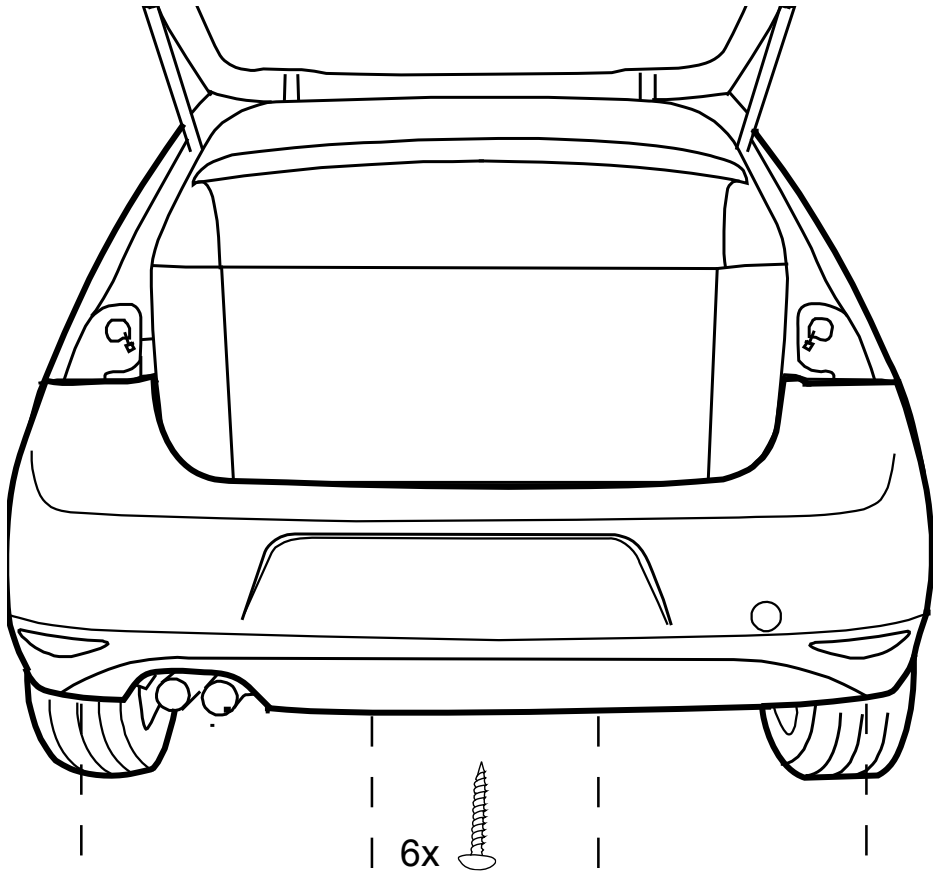
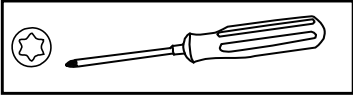

04

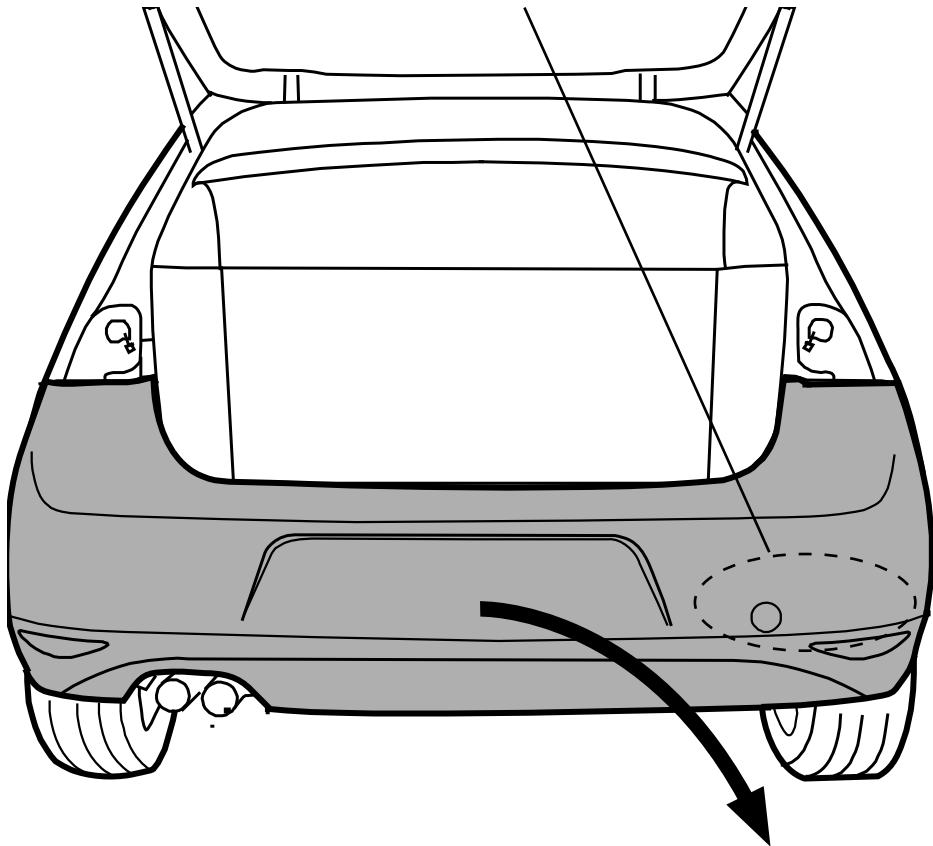
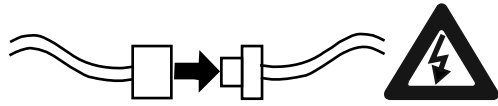

05

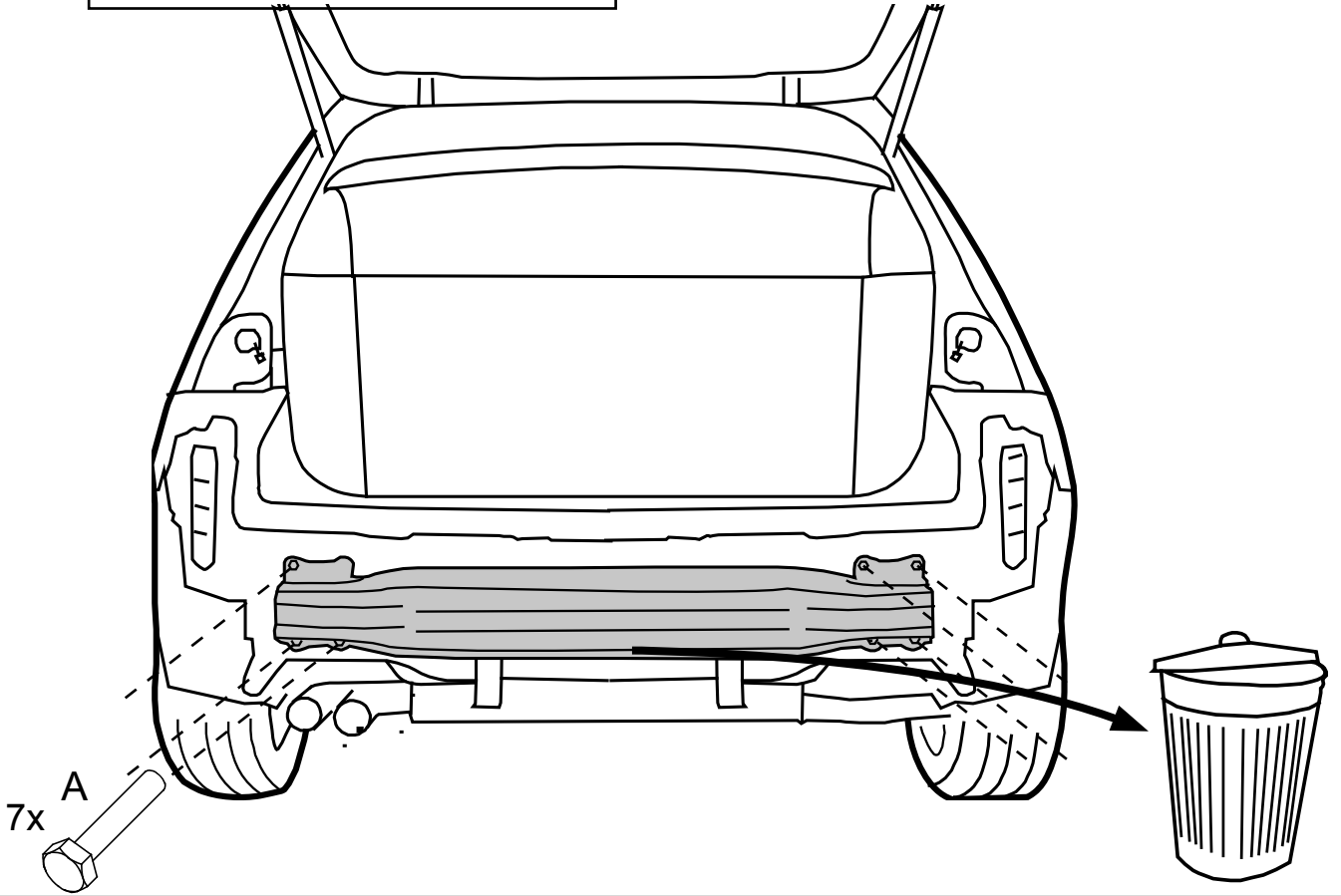
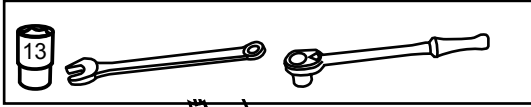

06

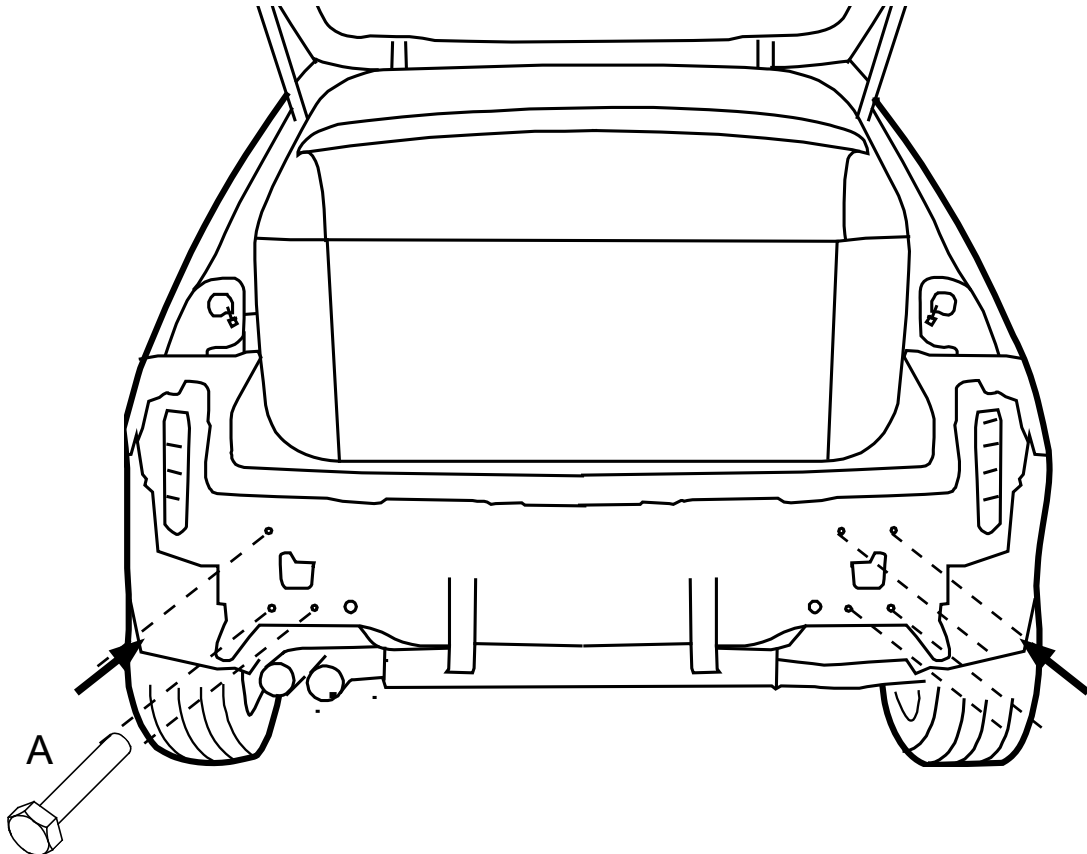
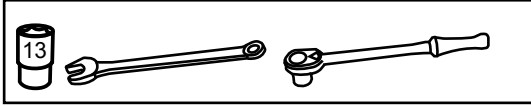

07

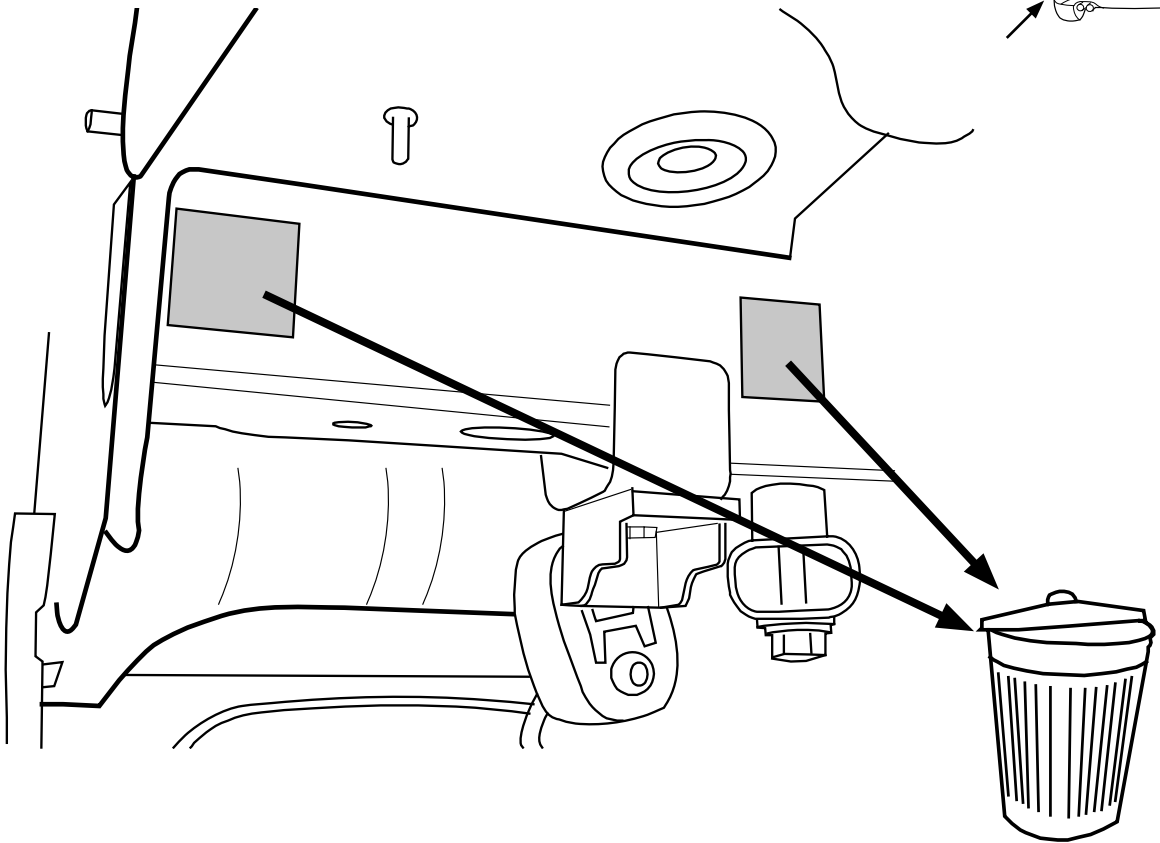
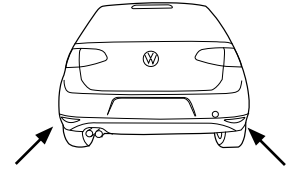

08

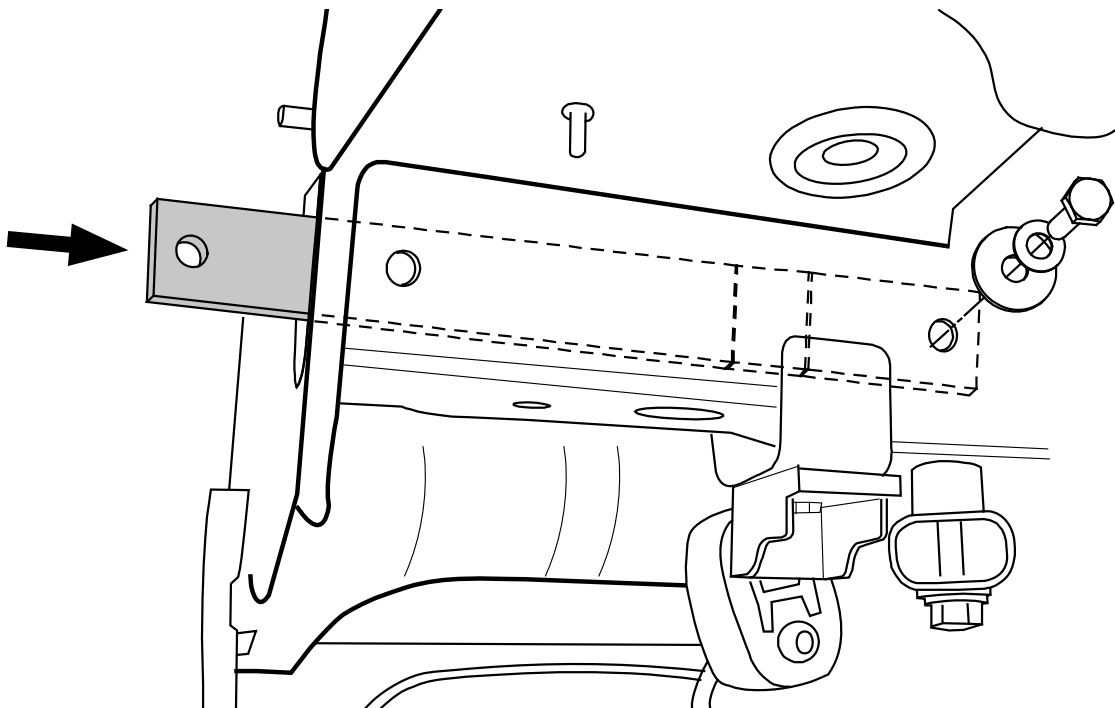
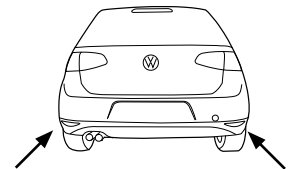
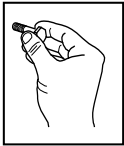

09

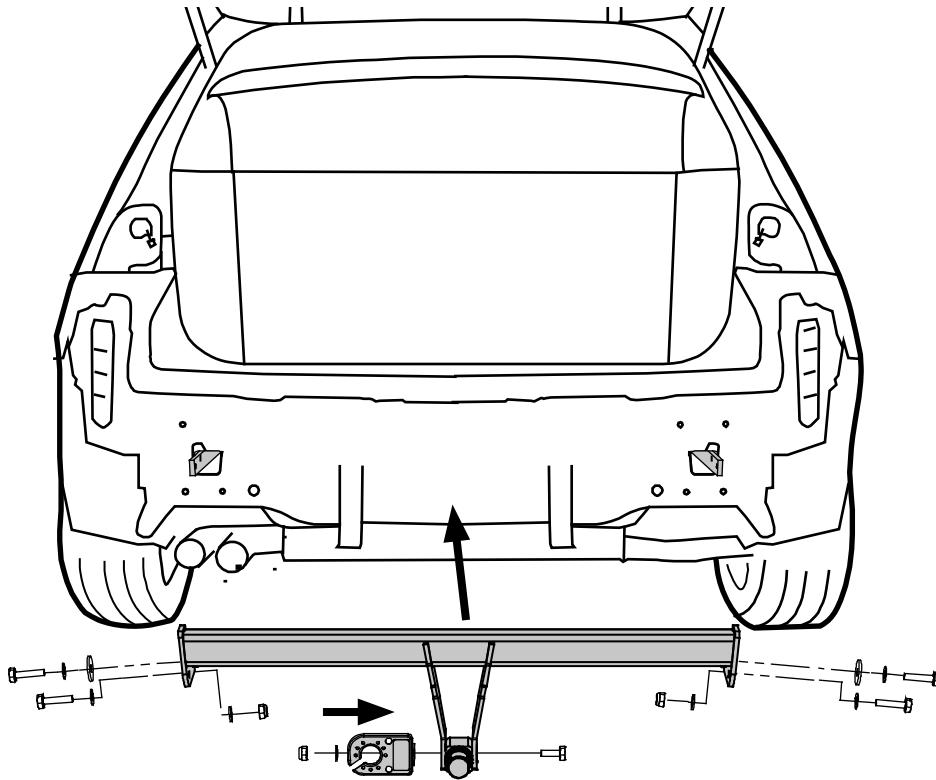

10

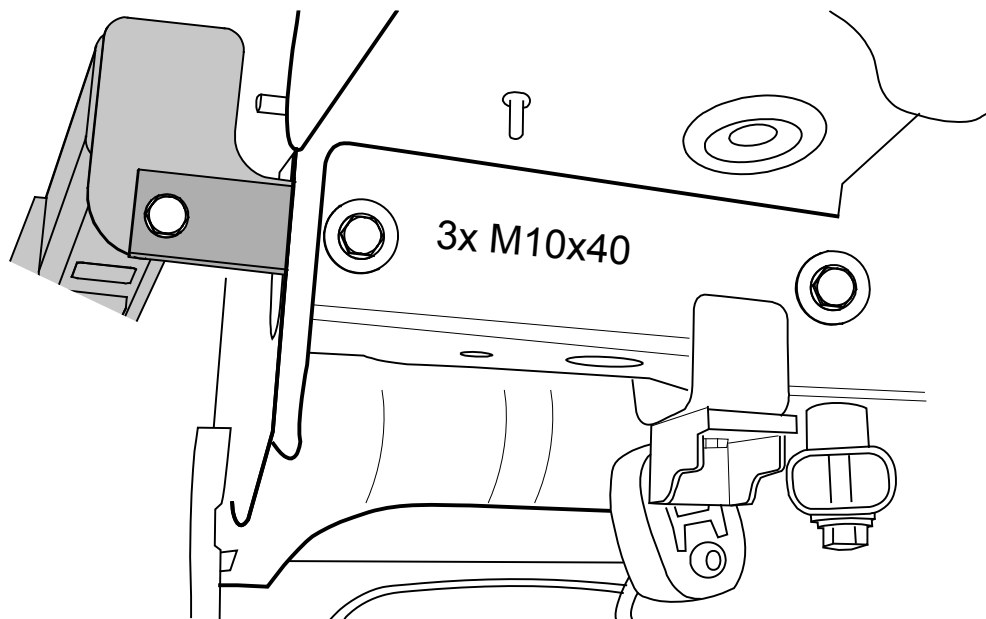
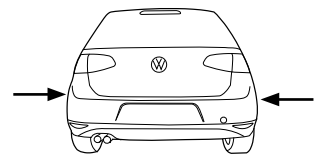
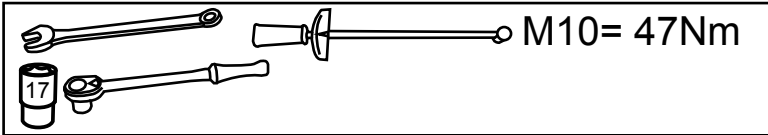

11

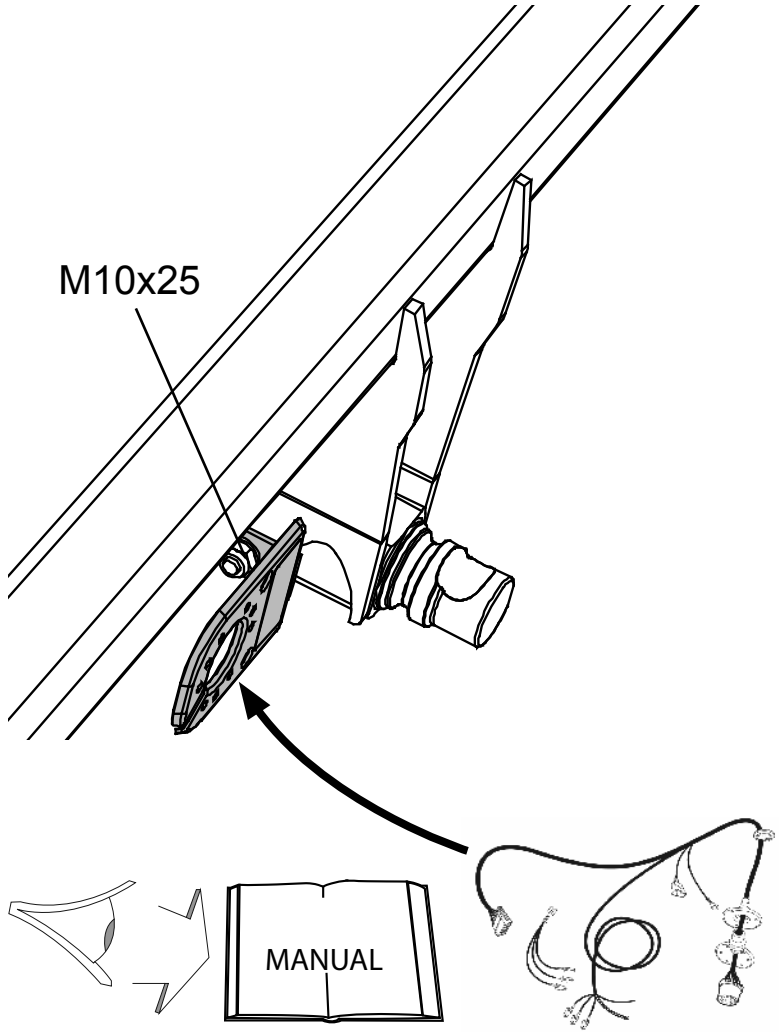
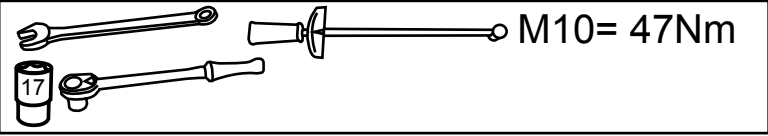

12

